

380 SERIES

Measures Temperature and Flow Rate and Calculates Energy

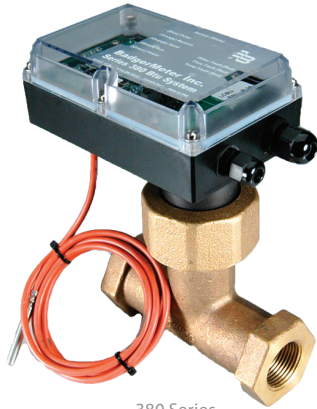

380 Series

Series 380 BTU system provides a low-cost system for metering hot and cold systems. The 380 measures flow and temperature differential to accurately calculate energy. With BACnet, Modbus RS-485, or scaled pulse output, it can interface with many existing control systems.

The rugged design incorporates an impeller flow sensor and two temperature probes, one mounted in the flow sensor tee and the other on either the supply or return line, depending on the application.

Commissioning can be done in the field via a computer connection or set up at the factory. Setup includes energy measurement units, measurement method, communication protocol, pulse output control, fluid density, and specific heat parameters (requires re-usable programming cable and software, see Ordering Information).

SPECIFICATIONS

Input Power	12 to 35 Vdc/12 to 28 Vac, 200 mA
Communication	Modbus RTU, BACnet MSTP
Output	Scaled pulse, open drain
Flow Calculation Accuracy	±2% of flow rate within range; 0.5% repeatability
Temperature Sensors	Meets IEC751 Class B
Flow Range	1 to 15 FPS
Pressure	Up to 400 psi

MATERIALS

Housing	Polycarbonate
Flow Sensor	PEEK
Potting Material	Polyurethane
Tee Material	Bronze

ENVIRONMENTAL

Fluid Temperature	-20 to 126 °C (-4 to 260 °F)
Ambient Temperature	-20 to 65 °C (-4 to 149 °F)

WARRANTY

Limited Warranty	1 year
------------------	--------

BACnet & Modbus

BACnet and Modbus protocols are standard features...easy integration with existing control systems

Easy installation

Minimal connections...simplify installation, saving time and cost

Stainless steel impeller

316 stainless steel impeller with tungsten carbide shaft

APPLICATIONS

- Energy management
- Data systems

Integrated flow & temperature

Integration of flow and temperature sensors with metering components...single solution for BTU metering

Two temperature probes

Rugged, compact design with two temperature probes

Sensor

PEEK sensor tip

DIMENSIONAL DRAWING

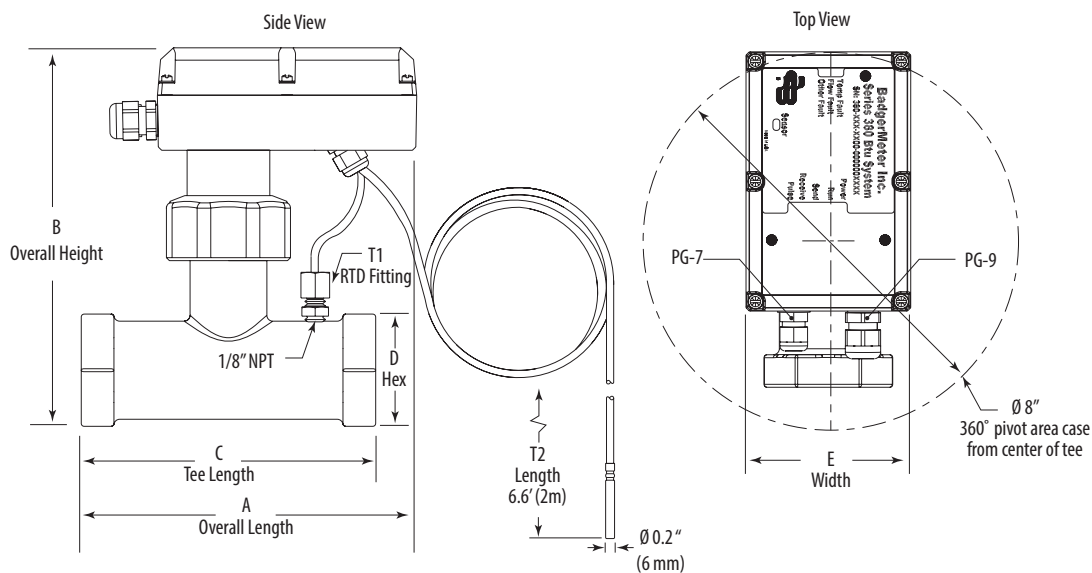

TEE/NPT SIZE	A	B	C	D	E
2" (51 mm)	7.9" (201 mm)	8.5" (216 mm)	7.8" (197 mm)	3.3" (84 mm)	3.5" (89 mm)
1.5" (38 mm)	7.3" (185 mm)	8.3" (209 mm)	6.7" (170 mm)	2.75" (70 mm)	3.5" (89 mm)
1.25" (32 mm)	7.1" (180 mm)	8.1" (204 mm)	6.2" (158 mm)	2.4" (60 mm)	3.5" (89 mm)
1" (25.4 mm)	6.7" (170 mm)	7.9" (201 mm)	5.4" (137 mm)	2" (51 mm)	3.5" (89 mm)
0.75" (19 mm)	6.7" (170 mm)	7.9" (201 mm)	5.4" (137 mm)	2" (51 mm)	3.5" (89 mm)

ORDERING INFORMATION

MODEL	MANUF. PART #	DESCRIPTION	MAX. GAL/MIN (GPM)
U001-0154	380207000-1202*,**	BTU system, hot and cold service, 3/4" tee NPT, with pulse, Modbus and BACNet outputs	25
U001-0155	380210000-1202*,**	BTU system, hot and cold service, 1" tee NPT, with pulse, Modbus and BACNet outputs	40
U001-0156	380212000-1202*,**	BTU system, hot and cold service, 1-1/4" tee NPT, with pulse, Modbus and BACNet outputs	70
U001-0157	380215000-1202*,**	BTU system, hot and cold service, 1-1/2" tee NPT, with pulse, Modbus and BACNet outputs	95
U001-0158	380220000-1202*,**	BTU system, hot and cold service, 2" tee NPT, with pulse, Modbus and BACNet outputs	150
U001-0114	A304-1M***	Programming Cable with CD for 380 Series	n/a

* Consult factory for availability information.

** Requires programming accessory.

*** Required to program 380 Series BTU meters (reusable). Standard USB type A to mini-B cable included. Software available from manufacturer's website, www.badgermeter.com

